

## Class Test Solution (SOM) 23-07-2018

### Answer key

1.	(c)	16.	(b)	31.	(a)	46.	(c)	61.	(d)
2.	(b)	17.	(c)	32.	(b)	47.	(c)	62.	(d)
3.	(b)	18.	(d)	33.	(d)	48.	(c)	63.	(d)
4.	(d)	19.	(d)	34.	(b)	49.	(c)	64.	(a)
5.	(c)	20.	(d)	35.	(d)	50.	(d)	65.	(c)
6.	(b)	21.	(b)	36.	(d)	51.	(a)	66.	(a)
7.	(d)	22.	(a)	37.	(c)	52.	(a)	67.	(a)
8.	(c)	23.	(a)	38.	(a)	53.	(a)	68.	(c)
9.	(c)	24.	(d)	39.	(b)	54.	(a)	69.	(c)
10.	(d)	25.	(c)	40.	(c)	55.	(b)	70.	(b)
11.	(d)	26.	(a)	41.	(a)	56.	(a)	71.	(d)
12.	(a)	27.	(a)	42.	(d)	57.	(c)	72.	(c)
13.	(c)	28.	(b)	43.	(d)	58.	(a)	73.	(a)
14.	(b)	29.	(b)	44.	(b)	59.	(b)	74.	(a)
15.	(c)	30.	(c)	45.	(d)	60.	(b)	75.	(a)



**IES MASTER**

Institute for Engineers (IES/GATE/PSUs)

Regd. office : F-126, (Upper Basement), Katwaria Sarai, New Delhi-110016 • Phone : 011-41013406

Mob. : 8010009955, 9711853908 • E-mail: ies\_master@yahoo.co.in, info@iesmaster.org

## CLASS TEST [SOM] SOLUTIONS

1. (c)

Let load shared by BD is  $P_B$  load shared by EC is  $P_C$

$$\sum M_A = 0$$

$$[(P_B) \times 2] + [P_C \times 4] = 1000 \times 3$$

$$P_B + 2P_C = 1500 \quad \dots(1)$$

Elongation in BD

$$\delta_B = \frac{P_B \times l}{E_a \cdot A_a}$$

Elongation in EC

$$\delta_C = \frac{P_C \times l}{E_s \cdot A_s}$$

From law of proportionality,

$$\frac{\delta_C}{4} = \frac{\delta_B}{2}$$

$$\delta_C = 2\delta_B$$

$$\frac{P_C \cdot l}{E_s \cdot A_s} = 2 \frac{P_B \cdot l}{E_a \cdot A_a}$$

$$\frac{P_C}{(20000) \times 4} = \frac{2P_B}{7000 \times 6}$$

$$P_C = 3.81P_B$$

From eqn. (1)

$$P_B + 2(3.81P_B) = 1500$$

$$P_B = 174.02 \text{ kg}$$

$$P_C = 662.99 \text{ kg}$$

2. (b)

Since the strain is proportional to the cable length, it varies from 0 at the end to the maximum value of 0.001 at the supports. The average strain is

$$\begin{aligned} \epsilon_{ave} &= \frac{\epsilon_{max}}{2} = \frac{0.001}{2} \\ &= 0.0005 \end{aligned}$$

The total elongation is

$$\delta = \epsilon_{ave} L = (0.0005) \times 200$$

$$= 0.10 \text{ m.}$$

3. (b)

Dilation is defined as the sum of the strain in all three coordinate directions. In the axial x direction,

$$\begin{aligned} \epsilon_x &= \frac{F}{EA} = \frac{2000 \text{ kN}}{\left(193 \times 10^6 \frac{\text{kN}}{\text{m}^2}\right) (0.049 \text{ m}^2)} \\ &= 2.1 \times 10^{-4} \end{aligned}$$

From Poisson's ratio,  $\nu = -\frac{\epsilon_z}{\epsilon_x} = -\frac{\epsilon_y}{\epsilon_x}$

$$\begin{aligned} \epsilon_z &= \epsilon_y = -\nu \epsilon_x \\ &= -(0.29)(2.1 \times 10^{-4}) \\ &= -6.09 \times 10^{-5} \end{aligned}$$

$$\begin{aligned} \text{Therefore } e &= \epsilon_x + \epsilon_y + \epsilon_z \\ &= (2.1 \times 10^{-4}) + (2)(-6.09 \times 10^{-5}) \\ &= 8.82 \times 10^{-5} \end{aligned}$$

4. (d)

Elongation due to temperature change is given by

$$\begin{aligned} \delta &= \alpha L (T_2 - T_1) \\ &= \left(9.4 \times 10^{-6} \frac{1}{^\circ\text{C}}\right) \\ &\quad (1000 \text{ mm})(40^\circ\text{C} - 10^\circ\text{C}) \\ &= 0.282 \text{ mm} \end{aligned}$$

Elongation is  $\delta = \frac{FL}{EA}$

$$\begin{aligned} F &= \frac{\delta EA}{L} \\ &= \frac{(0.000282 \text{ m}) \left(200 \times 10^6 \frac{\text{kN}}{\text{m}^2}\right) (0.0026 \text{ m}^2)}{1 \text{ m}} \\ &= 146.6 \text{ kN} \quad (147 \text{ kN}). \end{aligned}$$

5. (c)

Average shear stress  $\tau_{avg} = \frac{V}{ab}$



$$= \left( \frac{12 \times 10^3 \text{ Newton}}{125 \text{ mm} \times 240 \text{ mm}} \right)$$

$$= 0.4 \text{ MPa.}$$

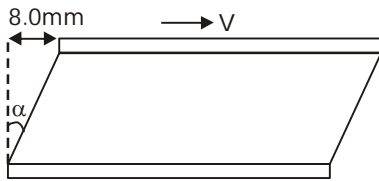

$$\text{Average shear strain } (\gamma_{\text{avg}}) = \frac{8}{50} = 0.16$$

$$\text{Shear modulus } (G) = \frac{\tau_{\text{avg}}}{\gamma_{\text{avg}}}$$

$$= \frac{0.4}{0.16}$$

$$= 2.5 \text{ MPa.}$$

6. (b)

FBD :

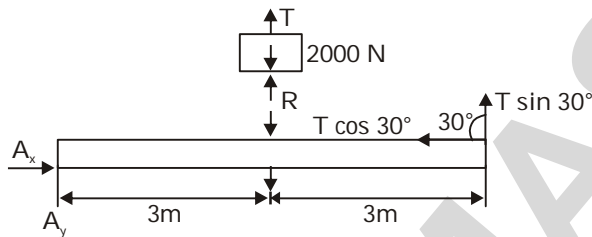

Apply equilibrium condition for the weight -

$$\Sigma F_y = 0$$

$$T + R = 2000 \text{ N}$$

Beam :

Similarly, applying the conditions of equilibrium-

$$\Sigma F_x = 0$$

$$\Rightarrow A_x - T \cos 30^\circ = 0$$

$$A_x = T \cos 30^\circ$$

and,  $\Sigma F_y = 0$

$$\Rightarrow A_y + T \sin 30^\circ - R = 0$$

$$A_y = R - 0.5 T.$$

Taking moment about the hinge A and equating to zero,

$$\Sigma M_A = 0$$

$$T \sin 30^\circ (6) - R(3) = 0$$

$$T = R$$

Substituting this in equation (a) we get,

$$T = R = 1000 \text{ N}$$

from equation (b), we get  $A_x = T \cos 30^\circ$

$$= 866.03 \text{ N}$$

from equation (c), we get -

$$A_y = R - 0.5 T$$

$$= 1000 - 0.5 (1000)$$

$$= 500 \text{ N.}$$

$$A = \sqrt{A_x^2 + A_y^2}$$

$$= 1000 \text{ N.}$$

7. (d)

8. (c)

Maximum stress will occur at the support where full weight of bar acts.

Initial case :

$$\text{Stress} = \frac{\text{Force}}{\text{Area}} = \frac{\gamma \times (A \times L)}{A}$$

(where  $\gamma$  = wt. per unit volume)

$$= \gamma \times L$$

Final case :

$$\text{Stress} = \frac{\gamma \times 4A \times 2L}{4A} = \gamma \times 2L$$

∴ Stress will be doubled.

9. (c)

The material which have poisson's ratio 0.5 does not show any volume change on loading.

$$\epsilon_v = (1 - 2\mu) \left[ \frac{\sigma_x + \sigma_y + \sigma_z}{E} \right]$$

If  $\mu = 0.5$

$$\epsilon_v = 0$$

From

$$E = 2G[1 + \mu]$$

$$E = 2G \times 1.5$$

$$\boxed{E = 3G}$$

10. (d)

**Statement I:** For linear elastic system,

$$\begin{aligned} \text{Strain energy, } U &= \frac{1}{2} \text{ stress} \times \text{strain} = \frac{1}{2} \times \sigma \times \epsilon \\ &= \frac{1}{2} \times E \times \epsilon \times \epsilon \\ &= \frac{1}{2} \times E \times \epsilon^2 \end{aligned}$$

$\therefore U \propto \epsilon^2$  [i.e. quadratic and not quartic (4<sup>th</sup> power)]

**Statement II:** In a linear elastic structural system for potential energy (U) to be minimum,

$$\frac{\partial U}{\partial P_i} = 0$$

This equation represents the compatibility condition at the point where  $P_i$  is acting.

**Statement III:**  $U_1 = \frac{P_1^2 L}{2AE}$ ;  $U_2 = \frac{P_2^2 L}{2AE}$ Due to combined action of  $P_1$  and  $P_2$ .

$$U = \frac{(P_1 + P_2)^2}{2AE} = \frac{P_1^2 L}{2AE} + \frac{P_2^2 L}{2AE} + \frac{2P_1 P_2 L}{2AE}$$

$$\Rightarrow U > U_1 + U_2$$

11. (d)

$$\text{C.G. of arm } \bar{x} = \frac{\left(\frac{2b}{5b}\right) W \cdot b + \left(\frac{b}{5b}\right) \cdot W \cdot 2b}{W}$$

$$\bar{x} = \frac{6}{5} b$$

$$\sum M_A = 0 \quad F_K = \frac{W \cdot \frac{6}{5} b}{b} = \frac{6}{5} W$$

$$\delta = \frac{F_K}{K} = \frac{6W}{5K}$$

$$12. (a) \quad \delta = \frac{8PD^3 N}{Gd^4} \Rightarrow \frac{\delta_2}{\delta_1} = 8$$

13. (c)

$$\text{Elongation of conical bar } (\delta_c) = \frac{\gamma L^2}{6E}$$

$$\text{Elongation of Prismatic bar } (\delta_p) = \frac{\gamma L^2}{2E}$$

$$\frac{\delta_c}{\delta_p} = \frac{\left(\frac{\gamma L^2}{6E}\right)}{\left(\frac{\gamma L^2}{2E}\right)} = \frac{1}{3}$$

14. (b)

15. (c)

Dimension of cube (a) = 50 mm

Compressive force (P) = 175 kN

$$P = -175 \text{ kN}$$

$$E = 100 \text{ GPa} = 100 \times 10^3 \text{ N/mm}^2$$

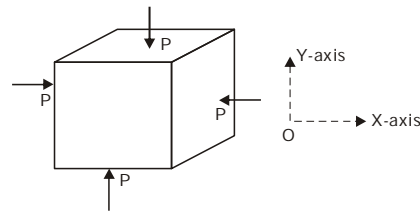
Poisson's ratio ( $\mu$ ) = 0.34

$$\sigma_x = \sigma_1 = \frac{-P}{a^2} = \frac{-175 \times 10^3}{(50)^2} = -70$$

MPa

$$\begin{aligned} \sigma_y = \sigma_2 &= \frac{-P}{a^2} = \frac{-175 \times 10^3}{50^2} \\ &= -70 \text{ MPa} \end{aligned}$$

$$\text{Strain in x-direction } \epsilon_1 = \frac{\sigma_1}{E} - \frac{\mu \sigma_2}{E}$$

$$\begin{aligned} &= \frac{-70}{100 \times 10^3} - \left( \frac{0.34 \times (-70)}{100 \times 10^3} \right) \\ &= -4.62 \times 10^{-4} \end{aligned}$$

$$\text{Similarly, } \epsilon_2 = \frac{\sigma_2}{E} - \frac{\mu \sigma_1}{E} = -4.62 \times 10^{-4}$$

$$\epsilon_z = \epsilon_3 = -\frac{\mu \sigma_1}{E} - \frac{\mu \sigma_2}{E}$$

$$= -\left[ \frac{0.34 \times (-70)}{100 \times 10^3} \right] - \left[ \frac{(0.34) \times (-70)}{100 \times 10^3} \right]$$

$$= 4.76 \times 10^{-4}$$

Volumetric strain

$$\begin{aligned} \epsilon_v &= \epsilon_1 + \epsilon_2 + \epsilon_3 \\ &= (-4.62 \times 10^{-4}) + (-4.62 \times 10^{-4}) + (4.76 \times 10^{-4}) \\ &= -4.48 \times 10^{-4} \end{aligned}$$

$$\epsilon_v = \frac{\text{change in volume } (\Delta V)}{\text{volume}}$$

$$\Delta V = -4.48 \times 10^{-4} \times (50)^3 = -56$$

mm<sup>3</sup>

Strain energy per unit volume,

$$\begin{aligned} U_v &= \frac{1}{2} \sigma_1 \epsilon_1 + \frac{1}{2} \sigma_2 \epsilon_2 \\ &= \frac{1}{2} [(-70) \times (-4.62 \times 10^{-4})] \\ &\quad + \frac{1}{2} [(-70) \times (-4.62 \times 10^{-4})] \\ &= 0.03234 \text{ N/mm}^2 \end{aligned}$$

Strain energy = U<sub>v</sub> × volume

$$\begin{aligned} &= 0.03234 \times (50)^3 \\ &= 4042.5 \text{ N-mm} \\ &= 4.0425 \text{ N-m} = 4.0425 \text{ Joule.} \end{aligned}$$

16. (b)

Strain matrix for 3-D strain

$$= \begin{bmatrix} \epsilon_{xx} & \frac{\phi_{xy}}{2} & \frac{\phi_{xz}}{2} \\ \frac{\phi_{yx}}{2} & \epsilon_{yy} & \frac{\phi_{yz}}{2} \\ \frac{\phi_{zx}}{2} & \frac{\phi_{zy}}{2} & \epsilon_{zz} \end{bmatrix}$$

Shear strain in yz plain

$$\begin{aligned} &= \frac{\phi_{yz}}{2} + \frac{\phi_{zy}}{2} \\ &= 0.002 + 0.002 = 0.004 \end{aligned}$$

Shear stress = Shear strain × GP

$$= 0.004 \times 80 \times 10^3$$

$$\boxed{\text{Stress} = 320 \text{ MPa}}$$

17. (c)

Let compressive stress induced in the bar is  $\sigma$  and force developed in the spring is  $F_s$ .

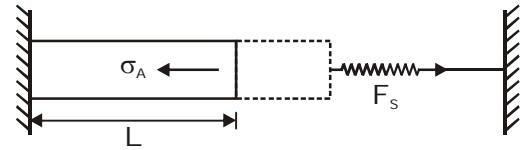

Net deflection of assembly will be zero

$$L \alpha T - \frac{\sigma}{E_s} \times L - \frac{F_s}{K} = 0$$

From eqn. of static equilibrium

$$\Sigma F_x = 0$$

$$F_s = \sigma A$$

$$L \alpha T - \frac{\sigma}{E} \times L - \frac{\sigma A}{K} = 0$$

$$L \alpha T = \sigma \left[ \frac{L}{E} + \frac{A}{K} \right]$$

$$\sigma = \frac{L \alpha T}{\frac{L}{E} + \frac{A}{K}}$$

$$\boxed{\sigma = \frac{\alpha T E}{1 + \frac{AE}{KL}}}$$

18. (d)

19. (d)

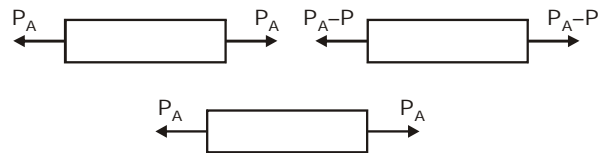

$$\Rightarrow \frac{P_A L}{3A \times E} + \frac{(P_A - P)K}{2 \times A \times E} + \frac{P_A \times L}{3A \times E} = 0$$

$$\Rightarrow \frac{2P_A}{3} + \frac{P_A - P}{2} = 0$$

$$\Rightarrow P_A \left[ \frac{2}{3} + \frac{1}{2} \right] = \frac{P}{2}$$

$$\Rightarrow P_A \left[ \frac{4+3}{6} \right] = \frac{P}{2}$$

(6)

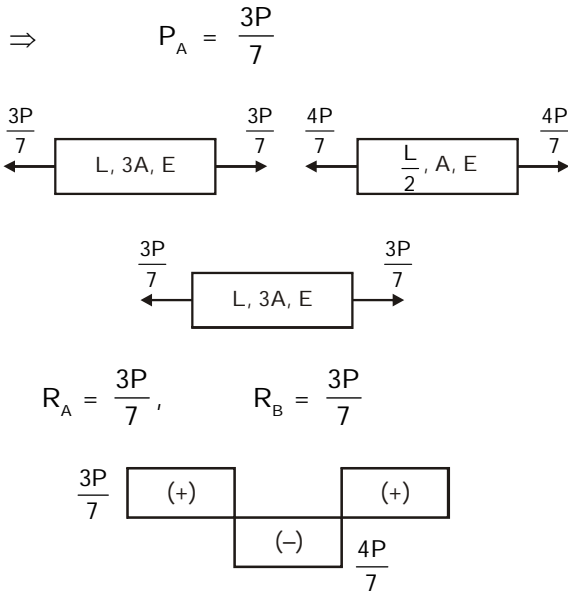

20. (d)

21. (b)

22. (a)

Due to repeated cyclical loading, the yield strength of metal reduces. This is termed as fatigue.

Both ductility and malleability are due to plasticity.

23. (a)

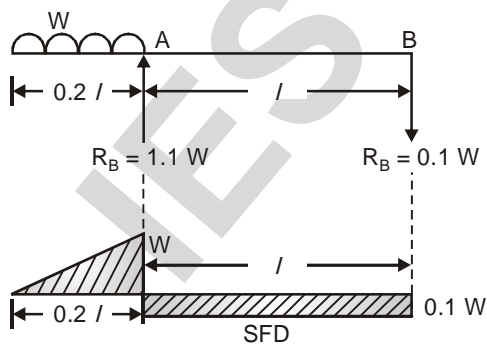

$\Sigma M_B = 0 \Rightarrow W \times 1.1l = R_A \times l$

$R_A = 1.1 W \uparrow$

$\Rightarrow R_B = 0.1 W \downarrow$

24. (d)

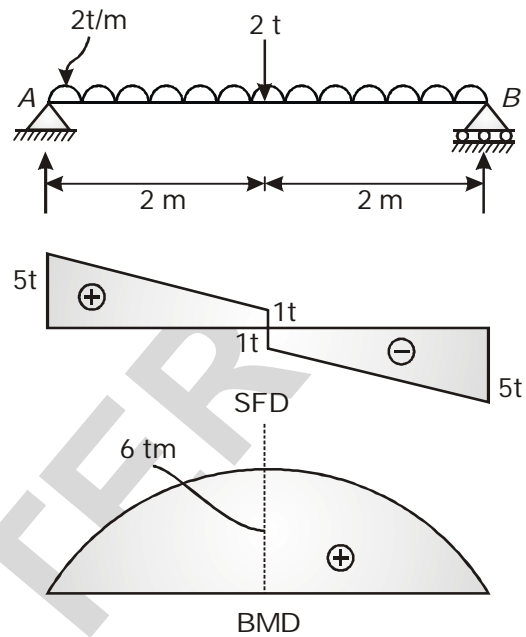

$\Sigma M_A = 0$

$\Rightarrow 2 \times 4 \times 2 + 2 \times 2 = 4 R_B$

$\Rightarrow R_B = 5 t$

$\therefore R_A = 5 t$

25. (c)

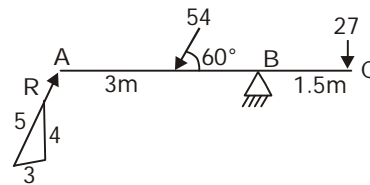

$\Sigma M_B = 0$

$-\frac{4}{5} R \times 6 + 54 \times \sin 60 \times 3 - 27 \times 1.5 = 0$

26. (a)

F.B.D. of the beam will be

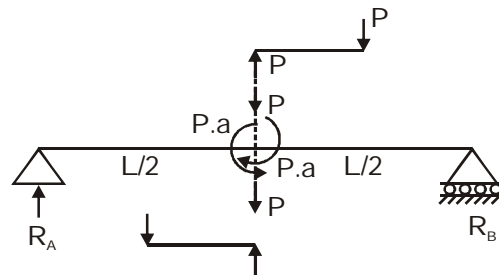

$R_A + R_B = 2P$

From symmetry

$$R_A = R_B = P$$

$$(B.M.) \text{ at } C = R_B \times L/2 = PL/2$$

This is case of simple bending so torsion will not induced, beam will be subjected only to shear force and bending moment.

27. (a)

28. (b)

29. (b)

The part AC is rigid so beam can be modified as

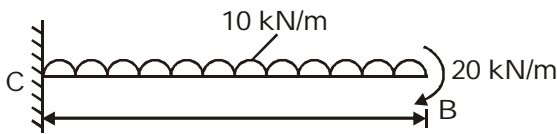

From principle of super portion

Slope at B = Slope due to udl + Slope due to B.M.

$$\begin{aligned} &= \frac{w l^3}{6EI} + \frac{M l}{EI} \\ &= \frac{10 \times (2)^3}{6EI} + \frac{20 \times 2}{EI} \\ &= \frac{1}{EI} [53.33] = \frac{53}{EI} \end{aligned}$$

Deflection at B

$\delta_B$  = Deflection due to udl + Deflection due to B.M.

$$\begin{aligned} &= \frac{w l^4}{8EI} + \frac{M l^2}{2EI} \\ &= \frac{10 \times (2)^4}{8EI} + \frac{20 \times (2)^2}{2EI} \\ &= \frac{20 + 20 \times 2}{EI} = \frac{60}{EI} \end{aligned}$$

30. (c)

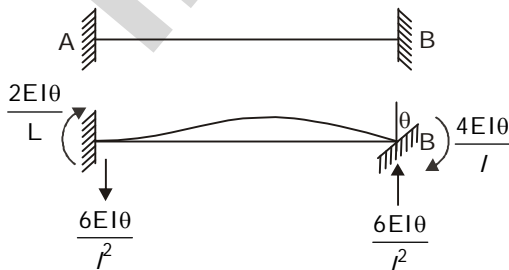

$$\text{Shear force} = \frac{6EI\theta}{l^2}$$

31. (a)

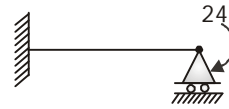

$$\begin{aligned} \frac{ML}{4EI} &= \theta_B \\ \theta_B &= \frac{24 \times 4}{4EI} \\ &= \frac{24}{EI} \end{aligned}$$

32. (b)

$$OA = (R - \delta) \text{ \& } AC = L/2$$

In  $\Delta OAC$

$$OA^2 + AC^2 = OC^2$$

$$\Rightarrow (R - \delta)^2 + (L/2)^2 = R^2$$

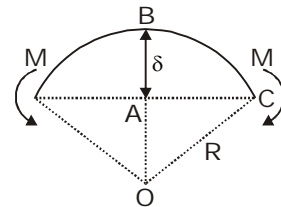

$$\Rightarrow -2R\delta + \delta^2 + L^2/4 = 0$$

$$\Rightarrow R = \frac{L^2}{8\delta} \quad [\because \delta^2 \text{ is very small}]$$

$$\therefore M = \frac{EI}{R} = \frac{8EI\delta}{L^2}$$

33. (d)

$$\delta_B = \frac{PL^3}{3EI} - \frac{PaL^2}{2EI} = 0 \Rightarrow \frac{a}{L} = \frac{2}{3}$$

34. (b)

1. Conjugate beam method is applicable for both prismatic and non-prismatic beams for which it is easy to draw  $\frac{M}{EI}$  diagram.
2. Conjugate beam is an imaginary beam, the loading of which is the  $\frac{M}{EI}$  diagram of real beam.
3. If real beam is determinate and stable, conjugate beam will also be determinate



and stable but if real beam is unstable conjugate beam will be indeterminate.

4. S.F. diagram of conjugate beam is the slope curve of given real beam.
5. B.M.D. of the conjugate beam is deflection curve/elastic curve of the given real beam.

35. (d)

Here, loading is upwards.

36. (d)

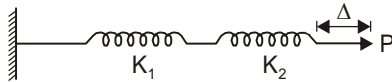

$$K = \frac{P}{\Delta}$$

$$\Delta = \Delta_1 + \Delta_2$$

$$\frac{P}{K} = \frac{P}{K_1} + \frac{P}{K_2} \Rightarrow \frac{1}{K} = \frac{1}{K_1} + \frac{1}{K_2}$$

37. (c)

Stress in plain AB

$$\sigma_1 = \frac{400 \times 1000}{4000}$$

$$\sigma_1 = 100 \text{ MPa}$$

Stress in plain BC

$$\sigma_2 = \frac{200 \times 1000}{4000}$$

$$\sigma_2 = 50 \text{ MPa}$$

Since AB and BC are mutually  $\perp$  and free from shear stress so, these plain will be principle plain and stress on these plain will be principal stress.

$$\sigma_1 = 100 \text{ MPa}$$

$$\sigma_2 = 50 \text{ MPa}$$

The normal and shear stresses along the plane  $45^\circ$  inclined with the normal to horizontal axis

$$\sigma = \frac{\sigma_1 + \sigma_2}{2} + \left( \frac{\sigma_1 - \sigma_2}{2} \right) \cos 2\theta$$

$$\sigma = \frac{100 + 50}{2} + \left( \frac{100 - 50}{2} \right) \times 0$$

$$\sigma = 75 \text{ MPa}$$

$$\tau = \left| \frac{\sigma_1 - \sigma_2}{2} \right| \sin 2\theta$$

$$\tau = \frac{100 - 50}{2} \times 1$$

$$\tau = 25 \text{ MPa}$$

38. (a)

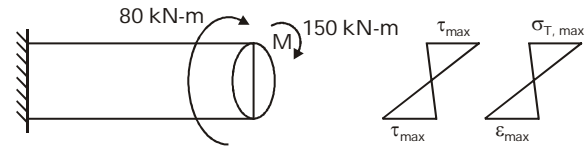

Stress diagram for combine loading

$$\text{where } \sigma = \frac{32 M}{\pi D^3} = \frac{32 \times 150 \times 10^6}{\pi \times (200)^3}$$

$$\sigma = 191 \text{ MPa}$$

$$\tau = \frac{16 T}{\pi D^3} = \frac{16 \times 80 \times 10^6}{\pi \times (200)^3}$$

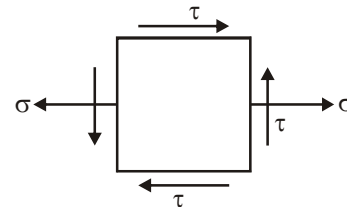

$$\tau = 51 \text{ MPa}$$

Centre of Mohr circle

$$= \frac{\sigma_x + \sigma_y}{2} = \frac{\sigma}{2} = 95.5$$

$$\text{Centre} = (0, 95.5)$$

Radius of Mohr circle

$$= \sqrt{\left( \frac{\sigma_x - \sigma_y}{2} \right)^2 + (\tau_{xy})^2}$$

$$\sigma_1 = 95.5 + 108.26 = 203.76 \text{ N/mm}^2$$

$$\sigma_2 = 95.5 - 108.26 = -12.76 \text{ N/mm}^2$$

$$r = 108.26$$

39. (b)

$$\sigma_x = 60 \text{ MPa}$$

$$\sigma_y = -40 \text{ MPa}$$

$$\tau_{xy} = \tau$$

$$\sigma_1 = 65 \text{ MPa}$$



$$\sigma_1 = \left( \frac{\sigma_x + \sigma_y}{2} \right) + \frac{1}{2} \sqrt{(\sigma_x - \sigma_y)^2 + 4\tau_{xy}^2} = 65$$

$$\frac{(60-40)}{2} + \frac{1}{2} \sqrt{(60+40)^2 + 4(\tau^2)}$$

$$55 = \frac{1}{2} \sqrt{100^2 + 4\tau^2}$$

$$\tau = 22.913 \text{ MPa.}$$

40. (c)

41. (a)

Principal plane is the plane on which only normal stress acts and shear stress is zero. Isotropic state of stress is indistinguishable with respect to the frame of reference

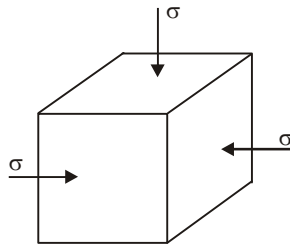

42. (c)

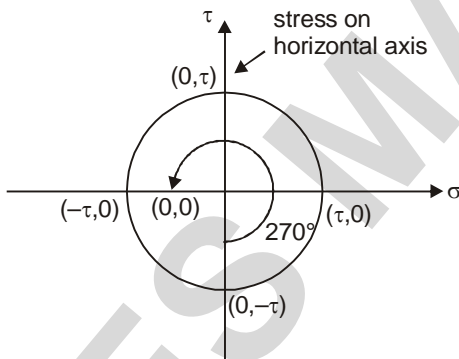

43. (d)

44. (b)

$$\epsilon_x = 0.0008$$

$$\epsilon_y = 0.0004$$

$$\phi_{xy} = 0.0003$$

Major principal strains

$$\epsilon_1/\epsilon_2 = \frac{\epsilon_x + \epsilon_y}{2} \pm \sqrt{\left( \frac{\epsilon_x - \epsilon_y}{2} \right)^2 + \left( \frac{\phi_{xy}}{2} \right)^2}$$

$$\epsilon_1/\epsilon_2 = \frac{0.0008 + 0.0004}{2} \pm \sqrt{\left( \frac{0.0008 - 0.0004}{2} \right)^2 + \left( \frac{0.0003}{2} \right)^2}$$

$$\epsilon_1/\epsilon_2 = 0.0006 \pm 2.5 \times 10^{-4}$$

$$\epsilon_1 = 8.5 \times 10^{-4}$$

$$\epsilon_2 = 3.5 \times 10^{-4}$$

Major principal stress

$$\sigma_1 = \frac{E}{1-\mu^2} (\epsilon_1 + \mu\epsilon_2)$$

$$\sigma_1 = \frac{2 \times 10^5}{1-(0.25)^2} (8.5 \times 10^{-4} + 0.25 \times 3.5 \times 10^{-4})$$

$$\sigma_1 = 200 \text{ MPa}$$

45. (d)

$$\gamma_{xy} = 2\xi_{45} - (\xi_x + \xi_y)$$

$$= (900 - 450) \times 10^{-6}$$

$$= 450 \times 10^{-6}$$

46. (c)

$$\text{Shear strain } e_{\max} - e_{\min} = \{1000 - (-600)\} \times 10^{-6} = 1600 \times 10^{-6}$$

47. (c)

$$\text{F.o.s.} = \frac{1000}{\frac{(1000+500)}{2}} = 1.33$$

$$48. (c) \sigma_{\max} = \frac{M}{\frac{\pi D^3}{32}}$$

$$\tau_{\max} = \frac{T D/2}{\frac{\pi D^4}{32}} = \frac{T}{\frac{\pi D^3}{16}} = \frac{M}{\frac{\pi D^3}{16}}$$

$$\Rightarrow \frac{\sigma_{\max}}{\tau_{\max}} = \frac{M}{\left( \frac{\pi D^3}{32} \right)} \bigg/ \frac{M}{\left( \frac{\pi D^3}{16} \right)} = 2$$

49. (c)

We know that in a 3D element,

Distortion energy =

$$\frac{1}{12G} [(\sigma_1 - \sigma_2)^2 + (\sigma_2 - \sigma_3)^2 + (\sigma_3 - \sigma_1)^2]$$

For two dimensional,  $\sigma_3 = 0$

∴ Distortion energy

$$= \frac{1}{12G} [\sigma_1^2 + \sigma_2^2 - 2\sigma_1\sigma_2 + \sigma_1^2 + \sigma_2^2]$$

$$= \frac{1}{12G} [2\sigma_1^2 + 2\sigma_2^2 - 2\sigma_1\sigma_2]$$

$$= \frac{1}{6G} [\sigma_1^2 + \sigma_2^2 - \sigma_1\sigma_2]$$

here,  $\sigma_1 = 90 \text{ N/mm}^2$

$$\sigma_2 = \sigma_3 = 0$$

$$\therefore \text{distortion energy} = \frac{1}{6G} \times 90^2 = \frac{1350}{G}$$

50. (d)

$$R_B = R_C = 0.3 \text{ kN}$$

$$M_{\max} = M_B = M_C = 0.3 \times 3$$

$$= 0.9 \text{ kN-m}$$

$$= 0.9 \times 10^6 \text{ N-mm}$$

$$= 9 \times 10^5 \text{ N-mm}$$

between Point B and C, bending moment is hogging and constant, so

$$\begin{aligned} \sigma_{\max} &= \frac{M_{\max} \cdot y}{I} \\ &= \frac{(9 \times 10^5) \times 70}{3 \times 10^6} = 21 \text{ MN/m}^2. \end{aligned}$$

51. (a)

52. (a)

53. (a) T-Section

54. (a)

Shear stress in web at level of junction = shear stress in flange at level of junction

$$\times \frac{\text{Width of flange}}{\text{Width of web}}$$

$$= 5 \times \frac{200}{50}$$

$$= 20 \text{ N/mm}^2$$

55. (b)

56. (a)

$$\text{Shear Flow} = \frac{VQ}{I}$$

$$Q = 40 \times 70 \times 110 = 308000$$

$$\begin{aligned} q &= \frac{V \cdot Q}{I} = \frac{2500 \times 308000}{1956 \times 10^8} \\ &= 3.9366 \approx 3.94 \text{ kN/m}. \end{aligned}$$

57. (c)

Diameter of pipe = 300 mm

Thickness = 10 mm

Pressure (p) = 20 N/mm<sup>2</sup>

$$\text{Hoop stress } (\sigma_n) = \frac{pd}{2t}$$

$$\sigma_1 = \frac{pd}{2t}$$

Longitudinal stress

$$\sigma_t = \sigma_2 = \frac{pd}{4t}$$

Maximum shear stress (in plane)

$$\tau_{\max} = \frac{\sigma_1 - \sigma_2}{2}$$

$$\tau_{\max} = \frac{pd}{8t}$$

$$\tau_{\max} = \frac{20 \times 300}{8 \times 10}$$

$$\tau_{\max} = 75 \text{ N/mm}^2$$

58. (a)

The angle of twist is

$$\phi = \frac{TL}{GJ}$$

J for a circular bar of diameter d is  $\frac{\pi d^4}{32}$ . The

total angle of twist,  $\phi_{\text{total}}$ , is equal to the sum of the angles of twist for the two different sections. The torque is the same for both sections.

$$\phi_{\text{total}} = \phi_1 + \phi_2$$

$$= \frac{T(2L)}{GJ_1} + \frac{TL}{GJ_2}$$

$$= \left( \frac{32TL}{\pi G} \right) \left( \frac{2}{d_1^4} + \frac{1}{d_2^4} \right)$$

$$= \left( \frac{32TL}{\pi G} \right) \left( \frac{2}{(2m)^4} + \frac{1}{(1m)^4} \right)$$



$$\phi_{total} = \frac{36TL}{\pi G}$$

$$T = \frac{\pi G \phi_{total}}{36L} = \frac{\pi G(0.0225 \text{ rad})}{36L}$$

$$= 0.000625 \frac{\pi G}{L}$$

59. (b)

If an unbraced column is braced at intermediate heights then the load required to buckle will increase by  $n^2$ .

The given column of 3m height is unbraced initially and having load carrying capacity of 100 kN.

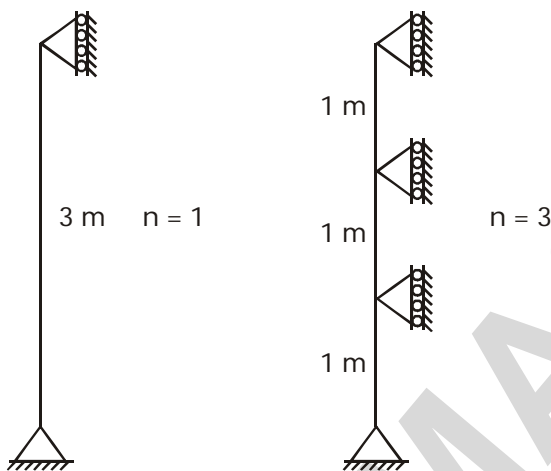

The load carrying capacity of the braced column will be

$$= n^2 \times 100$$

$$= (3)^2 \times 100$$

$$P_{Braced} = 900 \text{ kN}$$

60. (b)

Critical slenderness ratio =  $\lambda_c = \sqrt{\frac{\pi^2 E}{\sigma_c}}$

where E = Young's modulus of mild steel

$$= 2.1 \times 10^5 \text{ N/mm}^2$$

$\sigma_c$  = Crushing strength

$$= 3300 \text{ kg/cm}^2$$

$$= 323.73 \text{ N/mm}^2$$

$$\sigma_c = \sqrt{\frac{\pi^2 \times 2.1 \times 10^5}{323.73}} = 80$$

61. (d)

Assertion :

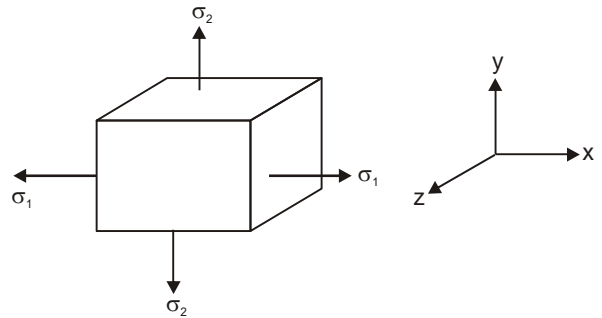

Plane state of stress,

$$\epsilon_x = \frac{\sigma_1}{E} - \frac{\mu\sigma_2}{E}$$

$$\epsilon_y = \frac{\sigma_2}{E} - \frac{\mu\sigma_1}{E}$$

$$\epsilon_z = -\frac{\mu\sigma_1}{E} - \frac{\mu\sigma_2}{E}$$

$$= -\frac{\mu}{E}(\sigma_1 + \sigma_2)$$

So, a plane state of stress does not results in a plane state of strain.

Reason :

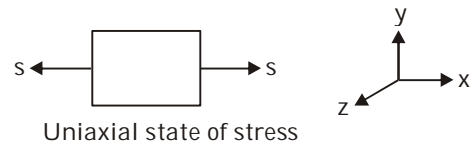

$$\epsilon_x = \frac{\sigma}{E}$$

$$\epsilon_y = -\frac{\mu\sigma}{E}$$

$$\epsilon_z = -\frac{\mu\sigma}{E}$$

So, a uniaxial state of stress results in a 3-dimension state of strain.

Assertion is wrong, Reason is correct.

Option (d) is correct.

62. (d)

$$\frac{\Delta V}{V} = \frac{\sigma_x + \sigma_y + \sigma_z}{E} (1 - 2\mu)$$

then,  $\frac{\Delta V}{V} \neq 0$  for  $\mu = 0.25$

$\Rightarrow$  Material is incompressible

Modulus of elasticity  $E = 3K(1 - 2\mu)$

63. (d)

Ductile materials have permanent strains.

64. (a)

65. (c)

66. (a)

67. (a)

68. (c)

69. (c)

70. (b)

71. (d)

72. (c)

Euler buckling loads represent the theoretical upper limit for compressive loading in the elastic range. In practice, actual buckling loads may be much less than Euler's theoretical value due to the great influence of crookedness, eccentricity and the instability to define end

conditions accurately. Accordingly, column loads are estimated using formulas which have one or more empirically adjusted terms.

73. (a)

74. (a)

For coplaner area,

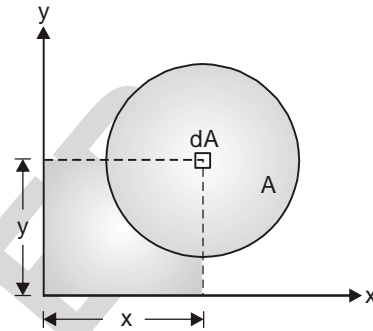

Centroidal co-ordinate is given by  $(x_c, y_c)$  where

$$x_c = \int_A \frac{xdA}{A} \text{ and } y_c = \int_A \frac{ydA}{A}$$

75. (a)